

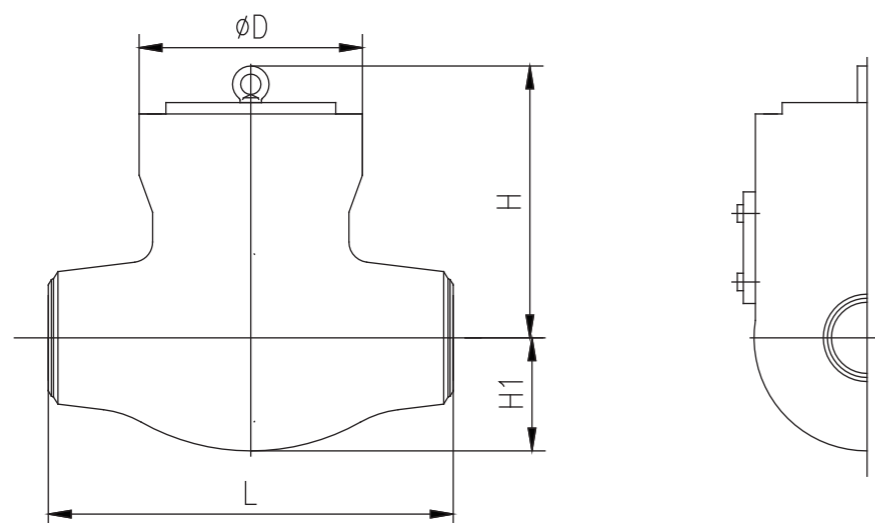

ANSI PRESSURE SEAL CAST STEEL TILTING DISC CHECK VALVES 美标铸钢压力自密封斜盘式阀瓣止回阀



Dimensions and Weights 尺寸及重量 (Class1500 ~ Class2500)

NPS / in 公称尺寸		2	3	4	6	8	10	12	14	16	18	20	24
Class 1500	L / mm	216	305	405	559	711	864	991	1067	1194	1537	1664	1743
	D / mm	170	185	215	260	365	455	480	510	665	745	860	990
	H / mm	185	185	295	380	460	610	700	730	790	840	900	980
	H1 / mm	80	110	120	145	180	230	260	280	335	380	445	565
	WT / kg	60	65	110	270	530	780	1210	1490	2170	2825	4150	5200
Class 2500	L / mm	279	368	457	610	762	914	1041	1118	1245	1397	1547	1727
	D / mm	170	170	185	285	365	420	465	520	560	650	710	815
	H / mm	160	160	185	360	360	450	580	620	775	855	890	970
	H1 / mm	80	80	120	165	180	210	250	275	335	345	385	465
	WT / kg	60	65	105	245	520	860	1250	1750	2350	3200	4540	5700

Notes: * Dimensions can be designed according to customer's requirement. 注: 带 * 尺寸可根据客户要求设计制造。

GLOBE VALVES 截止阀

I、Rational structure, reliable sealing, excellent performance and nice molding.
II、Co-radix alloy welded sealing surface, anti-wearing, erosion-proof abrasion-proof and prolong service life.
III、There is backseat structure in the valve, so the sealing is reliable.
IV、Disc and sealing surface of seat utilize awl seal, with small strength to blow down scour resistance seal credible.
V、The part materials and flange dimensions may be designed according to different working condition and customer's requirement.

Features 结构特点

- 1、产品结构合理、密封可靠、性能优良和造型美观。
- 2、密封面堆焊硬质合金，耐磨、耐蚀、抗擦伤性能好和使用寿命长。
- 3、阀门设有上密封座，密封可靠。
- 4、阀瓣与阀座密封面采用锥面密封，关闭力小、耐冲刷、密封可靠。
- 5、零件材质及法兰尺寸可根据实际工况或用户要求合理选配，满足各种工程需要。

Technical Data 技术参数

Size 公称尺寸: NPS 2~18、DN 50~400

Pressure Ratings 压力等级: Class 150~Class 900、PN 16~PN 100

Temperature 适用温度: -196°C~593°C

Design Standard 设计标准: DIN 3356、ASME B16.34、BS 1873

Face to Face 结构长度: DIN EN558、ASME B16.10

Flanged Ends 法兰端: DIN EN1092、ASME B16.5

Butt-welding Ends 对焊端: ASME B16.25

Test and Inspection 试验和检验: ISO 5208、API 598、DIN 3230

Drive Means: Manual, Electric Actuator, Pneumatic Actuator

驱动方式: 手动, 电动, 气动

Notes: The flange sizes and butt-welding dimensions of serial valves can be designed according to customer's requirement.

注: 系列阀门法兰端和对焊端尺寸可根据客户要求设计制造



GLOBE VALVES 截止阀

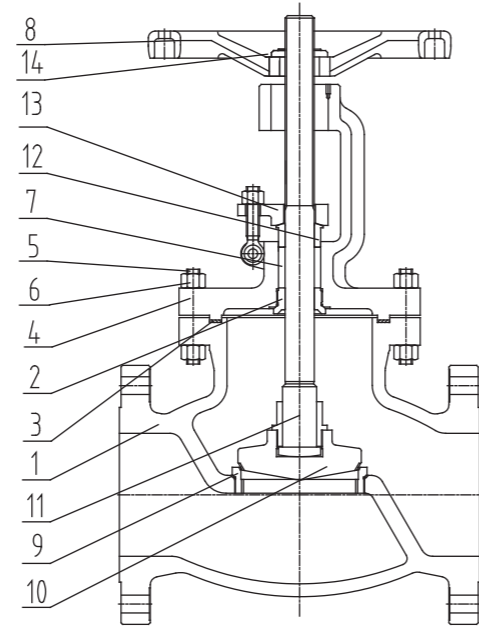

ANSI GLOBE VALVES 美标截止阀

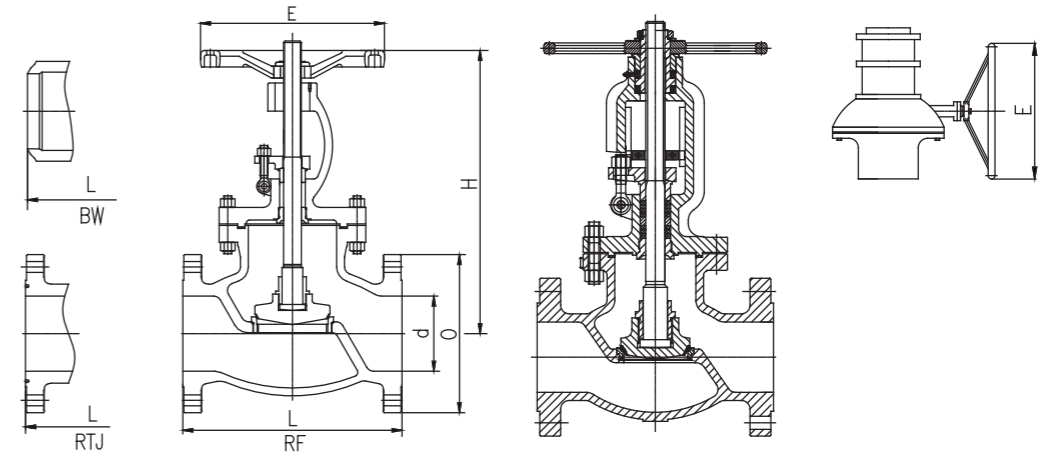

Dimensions and Weights 尺寸及重量 (Class150 ~ Class900)

Class 压力级	NPS(in) 公称尺寸	Dimensions 尺寸 / mm						Weight 重量 / kg	
		d	L		O	H	E	RF/RTJ	BW
			RF/BW	RFJ					
Class 150	2	51	203	216	150	338	200	21	17
	2½	64	216	229	180	373	250	28	20
	3	76	241	254	190	396	280	35	27
	4	102	292	305	230	476	300	58	47
	6	152	406	419	280	524	350	100	86
	8	203	495	508	345	588	400	160	138
	10	252	622	635	405	738	600	253	219
	12	305	698	711	485	862	650	498	362
	14	337	787	800	535	950	600	550	491
Class 300	16	387	914	927	595	994	600	724	650
	18	438	978	991	635	1140	600	1400	1250
	2	51	267	283	165	354	200	25	19
	2½	64	292	308	190	389	280	38	29
	3	76	318	334	210	421	280	49	38
	4	102	356	372	255	496	350	76	58
	6	152	444	460	320	675	400	168	137
	8	203	559	575	380	912	600	282	237
	10	252	622	638	445	949	700	485	419
Class 600	12	305	711	727	520	1032	600	724	632
	14	337	838	854	585	1130	600	1125	975
	16	387	864	880	650	1310	600	1650	1450
	2	51	292	295	165	397	250	36	29
	2½	64	330	333	190	446	280	50	40
	3	76	356	359	210	496	350	78	64
	4	102	432	435	275	599	400	120	91
	6	152	559	562	355	791	600	284	227
	8	200	660	663	420	1014	600	543	460
Class 900	10	248	787	790	510	1180	700	1000	762
	12	298	838	841	560	1397	600	1350	1050
	2	47	368	371	215	590	300	95	75
	2½	57	419	422	245	660	350	138	112
	3	73	381	384	240	699	400	108	85
	4	98	457	460	290	795	450	195	158
	6	146	610	613	380	1108	600	435	360
	8	191	737	740	470	1184	600	720	597

Material Specifications 材料规范

NO. 序号	Parts 零件名称	Materials 材料			
		Standard 标准	Low Temp. Service 低温	High Temperature 高温	SS 不锈钢
1	Body 阀体	A216 WCB	A352 LCB	A217 WC6	A351 CF8M
2	Backseat 上密封座	A182 F6a	A182 F304	A182 F304	A182 F316
3	Bonnet Gasket 垫片	Graphite + 316 柔性石墨 + 316	Graphite + 316 柔性石墨 + 316	Graphite + 316 柔性石墨 + 316	Graphite + 316 柔性石墨 + 316
4	Bonnet 阀盖	A216 WCB	A352 LCB	A217 WC6	A351 CF8M
5	Bonnet bolt 螺柱	A193 B7	A320 L7	A193 B16	A193 B8M
6	Bonnet Nut 螺母	A194 2H	A194 4	A194 4	A194 8M
7	Packing 填料	Graphite + 304 柔性石墨 + 304	Graphite + 304 柔性石墨 + 304	Graphite + 304 柔性石墨 + 304	Graphite + 316 柔性石墨 + 316
8	Handwheel 手轮	Cast Iron 铸铁	Cast Iron 铸铁	Cast Iron 铸铁	Cast Iron 铸铁
9	Seat 阀座	A105	A182 LF2	A182 F11	—
10	Disc 阀瓣	A105	A182 LF2	A182 F11	A182 F316
11	Stem 阀杆	A182 F6a	A182 F304	A182 F6a	A182 F316
12	Gland 填料压套	A276 410	A276 410	A276 304	A276 316
13	Gland Flange 填料压板	SS	CS	CS	SS
14	Handwheel Nut 锁紧螺母	SS	CS	CS	SS

Note: Materials can be selected according to customer's requirement. 注：材料可根据用户要求合理选用。



DIN GLOBE VALVES 德标截止阀

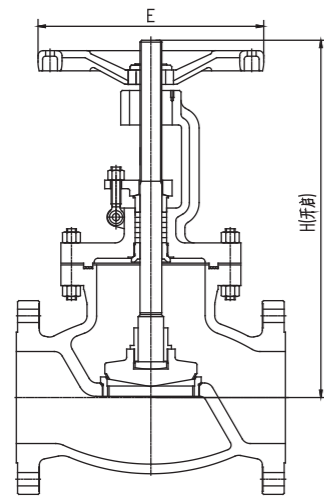

Yoke 带支架
PN63, DN≥200
PN100, DN≥200

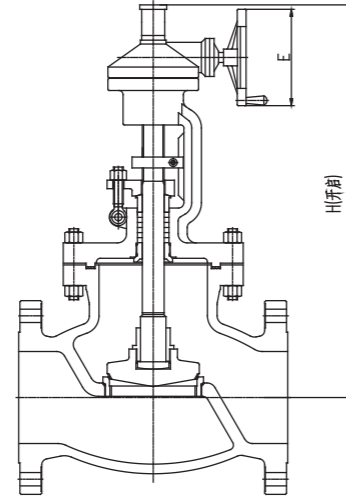

Impact Handwheel 撞击手轮
PN16, PN25, DN≥250
PN40, DN≥150
PN63, DN≥100

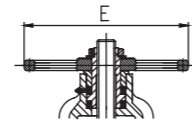

Gear Operation 齿轮操作
PN16, PN25, DN≥350
PN40, DN≥200
PN63, DN≥150
PN100, DN≥100

Dimensions and Weights 尺寸及重量 (PN16 ~ PN100)

DN / mm 公称尺寸		50	65	80	100	150	200	250	300	350	400
L / mm		230	290	310	350	480	600	730	850	980	1100
PN16	H / mm	305	354	402	437	541	699	815	914	1189	1350
	E / mm	200	250	280	300	350	400	600	600	600	600
	Weight重量 / kg	20	25	35	50	100	210	446	648	805	1050
PN25	H / mm	325	363	415	453	556	744	864	948	1269	1450
	E / mm	200	250	250	300	350	400	550	600	560	650
	Weight重量 / kg	22	27	38	55	105	220	450	660	810	1100
PN40	H / mm	325	370	430	480	589	783	888	965	1285	1512
	E / mm	200	250	250	350	500	560	600	650	610	610
	Weight重量 / kg	24	30	41	60	110	225	460	670	830	1120
DN / mm 公称尺寸		50	65	80	100	150	200	250	300	350	400
L / mm		300	340	380	430	550	650	775	900	1025	1150
PN63	H / mm	305	354	402	437	541	699	815	914	1189	1350
	E / mm	250	250	350	450	560	600	700	610	610	610
	Weight重量 / kg	26	33	45	65	120	230	470	680	850	1130
PN100	H / mm	325	363	415	453	556	744	864	948	1269	1450
	E / mm	350	350	450	500	610	610	610	610	610	610
	Weight重量 / kg	27	34	46	67	125	235	480	690	860	1150

PRESSURE SEAL GLOBE VALVES 压力自密封截止阀

I、Rational structure, reliable sealing, excellent performance and nice molding.
 II、Regardless of operating-temperature changes, the bonnet joint remains leak proof. This is insured by stainless steel inlay in the body gasket area. The sealing pressure is in direct proportion to the internal pressure.
 III、Advanced pressure seal designed body and pure graphite gasket rings to ensure high tightness and comply with the healthy and safe environment requirements for fugitive emissions control.

Features 结构特点

- 1、产品结构合理、密封可靠、性能优良和造型美观。
- 2、阀体垫片上嵌入不锈钢，不管工作温度如何变化，阀盖与阀体的连接始终保持无泄漏，密封压力与内部压力相均衡。
- 3、采用压力密封结构设计的体腔和纯石墨密封环以便得到高的紧密性，保证了使用安全，即使在恶劣的环境下都能保证体腔无外漏。

Technical Data 技术参数

Size 公称尺寸：NPS1 ~ 12

Pressure Ratings 压力等级：Class 900 ~ Class 2500

Temperature 适用温度：-29°C ~ 593°C

Design Standard 设计标准：ASME B16.34

Face to Face 结构长度：ASME B 16.10

Flanged Ends 法兰端：ASME B 16.5

Butt-welding Ends 对焊端：ASME B 16.25

Test and Inspection 试验和检验：ISO 5208、API 598

Drive Means 驱动方式：Manual, Electric actuator, Pneumatic actuator

驱动方式：手动，电动，气动

Note: The flange sizes and butt-welding dimensions of serial valves can be designed according to customer's requirement.

注：系列阀门法兰端和对焊端尺寸可根据客户要求设计制造。



ANSI PRESSURE SEAL GLOBE VALVES 美标压力自密封截止阀

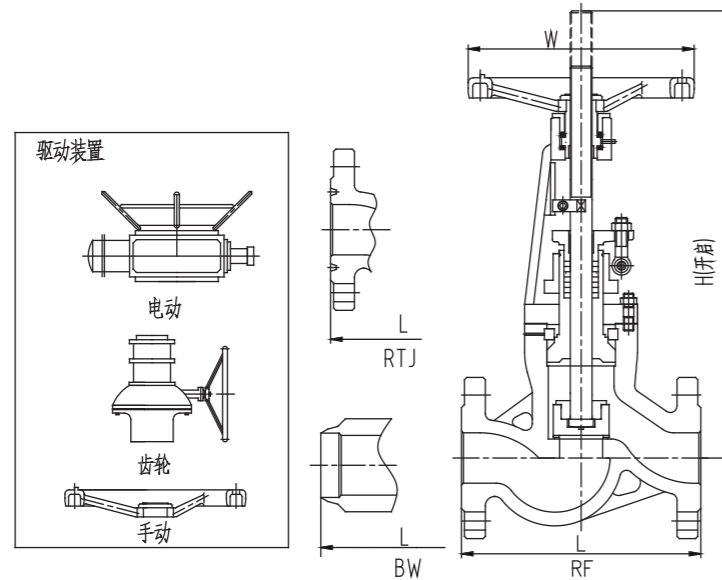

Note: Manual for NPS4 and smaller. 注：NPS4及以下用手轮操作。

Dimensions and Weights 尺寸及重量 (Class900 ~ Class2500)

Class 压力级	NPS(in) 公称尺寸	Dimensions 尺寸 / mm						Weight 重量 / kg	
		d	L		O	H	E	RF/RTJ	BW
			RF/BW	RFJ					
Class 900	2	47	368	371	215	619	350	84	58
	2½	57	419	422	245	641	350	100	74
	3	73	381	384	240	721	450	110	84
	4	98	457	460	290	850	500	179	137
	6	146	610	613	380	1225	610	441	378
	8	191	737	740	470	1350	610	1050	945
Class 1500	2	47	368	371	215	619	350	84	58
	2½	57	419	422	245	641	350	116	84
	3	70	470	473	265	835	500	143	100
	4	92	546	549	310	857	560	236	168
	6	136	705	711	395	1230	610	918	781
	8	178	832	842	485	1800	610	1764	1502
Class 2500	2	38	451	454	235	616	400	105	74
	2½	47	508	541	265	781	500	163	116
	3	57	578	584	305	800	560	221	147
	4	73	673	683	355	1300	610	525	368
	6	111	914	927	485	1370	610	1313	973
	8	146	1022	1038	550	2160	610	2520	2100

FORGED STEEL GATE VALVES 锻钢闸阀

Technical Data 技术参数

Pressure Rating 压力等级：Class800 ~ Class1500
 Basic Design 设计标准：API 602
 Threaded end 螺纹端尺寸：ASME B 1.20.1
 Socket-weld 承插口端尺寸：ASME B 16.11
 Test and Inspection 试验和检验：API 598

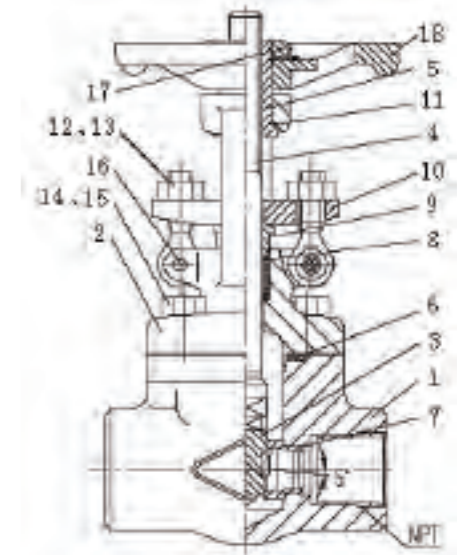

Material Specifications 材料规范

NO. 序号	Parts 零件名称	Materials 材料
		ASTM
1	Body 阀体	A105
2	Bonnet 阀盖	A105
3	Wedge 闸板	A217
4	Stem 阀杆	A182 F6a
5	Stem Nut 阀杆螺母	Bronze 青铜
6	Gasket 垫片	304 SS
7	Seat 阀座	A105
8	Packing 填料	Graphite+304 柔性石墨+304
9	Gland 填料压套	A276 420
10	Gland Flange 填料压板	CS 碳钢
11	Thrust Washer 止推垫片	A182 F304
12	Nut 螺母	A194 2H
13	Eyebolt 活结螺栓	A193 B7
14	Bolt 螺栓	A193 B7
15	Nut 螺母	A194 2H
16	Pin 圆柱销	CS 碳钢
17	Handwheel Nut 锁紧螺母	CS 碳钢
18	Handwheel 手轮	Cast Iron 铸铁

Note: The materials can be selected according to customer's requirement. 注：材料可根据客户要求合理选用。